

TONE

Touch 04 Operating Manual

March 2026

Version 2.0



Disclaimer

Congratulations on purchasing your new TONE product. The information in this document affects your safety and your legal rights and responsibilities. Read this entire document carefully to ensure proper configuration before use. Failure to read and follow instructions and warnings in this document may result in serious injury to yourself or others, damage to your TONE product, or damage to other objects in the vicinity. This document and all other collateral documents are subject to change at the sole discretion of TONE. For up-to-date product information, visit <http://www.tone-brewer.com> and click on the product page for this product.

By using this product, you hereby signify that you have read this disclaimer and warning carefully and that you understand and agree to abide by the terms and conditions herein. You agree that you are solely responsible for your own conduct while using this product, and for any consequences thereof. You agree to use this product only for purposes that are proper and in accordance with all applicable laws, rules, and regulations, and all terms, precautions, practices, policies and guidelines TONE has made and may make available.

TONE accepts no liability for damage, injury or any legal responsibility incurred directly or indirectly from the use of this product. The user shall observe safe and lawful practices including, but not limited to, those set forth in this document.

Copyright © 2026 by Barista Productions GmbH

All rights reserved. No part of this publication may be reproduced, distributed, or transmitted in any form or by any means, including photocopying, recording, or other electronic or mechanical methods, without the prior written permission of the publisher. For permission requests, write to the publisher, addressed at the address below.

TRADEMARKS

TONE is a trademark of Cup&Cino Kaffeesystem Vertrieb GmbH & CoKG (abbreviated as „TONE“) and its affiliated companies. Names of products, brands, etc.. appearing in this manual are trademarks or registered trademarks of their respective owner companies.

1. PROPER USE

This machine is only intended for the use for which it was basically developed. Any other use shall be considered ill-suited and improper. The manufacturer shall not be considered responsible for any damages caused by improper use. The electric safety to the machine is achieved only when the machine is correctly connected to a grounded electric system. This fundamental requirement shall be assessed by qualified personnel.

Manufacturer and installer shall not be held responsible for any damages caused by the lack or inefficiency of system grounding.

1.1 FOR YOUR SAFETY

Read and follow the instructions in these operating instructions in order to operate this machine safely. Do not carry out any independent modifications or repairs on the device.

The following warning symbols are used in these operating instructions.

1.2 EXPLANATION OF SAFETY WARNINGS

DANGER!

Failure to observe the warning can result in danger to life and limb.

WARNING!

Failure to observe the warning can result in material damage.

CAUTION!

Matters which should be taken into account when using the appliance.

INFORMATION FOR CORRECT DISPOSAL OF THE PRODUCT IN ACCORDANCE WITH EC DIRECTIVE 2012/19/EU

This product must not be disposed of as urban waste at the end of its working life. It must be taken to a special waste collection centre licensed by local authorities or to a dealer providing

this service. Separate disposal of the product will avoid possible negative consequences for the environment and for health resulting from inappropriate disposal, and will enable the constituent materials to be recovered, with significant savings in energy and resources.

OBSERVE THE FOLLOWING SAFETY INSTRUCTIONS AT ALL TIMES:

The appliance is only to be installed in locations where its use and maintenance is restricted to trained personal.

DANGERS TO CHILDREN AND OTHER PERSONS!

This appliance can be used by children aged from 8 years and above and persons with reduced physical, sensory or mental capabilities or lack of experience and knowledge if they have been given supervision or instruction concerning use of the appliance in a safe way and understand the hazards involved. Children shall not play with the appliance. Cleaning and user maintenance shall not be made by children without supervision.

DANGER DUE TO FAULTY OPERATION!

Improper use of the appliance can result in damage or injury.

- Do not use the appliance barefoot or when hands / feet are wet.
- Unplug the appliance from the electric system and turn off water supply before carrying out any cleaning and ordinary maintenance.
- Do not put the appliance under a jet of water, nor plunge it into water to clean it.
- Do not leave the appliance turned-on and unattended for long periods (e.g. 1 day)

NO LIQUID MAY OVERFLOW ON THE DEVICE PLUG CONNECTION

- In order to ensure the efficiency and correct functioning of the appliance, it is necessary to follow the instructions provided by the manufacturer and to carry out its ordinary maintenance.
- The appliance shall be installed so that the highest surface is at least 1 meter high.
- The appliance shall be placed on a level horizontal surface to ensure a safe use.
- The temperature range of the environment surrounding the appliance shall be included between 5°C and 30°C. In case the appliance is temporarily placed in an environment where the temperature is below 0°C, contact a local Technical Service authorized by the manufacturer.
- The machine shall be placed on a surface guaranteeing secure support.
- The appliance has to be bolted onto the working surface using a pair of slotted countersunk screws (M8, stainless).
- The machine must be connected exclusively to an appropriate cold drinking water source, in compliance with national norms and rules. The pressure of the incoming water must be between 0.3-0.4 MPa. If this is not met, install a pressure reducer / regulator according to the requirements.
- A shut-on tap must be installed between machine water hose and water system to block water flow in case of necessity.
- When installing the appliance, use exclusively the current hose-set provided with the appliance itself.
- In case of appliance breakdown and/or malfunctioning, turn the main switch OFF and refrain from trying to repair it. Then contact a local Technical Service that has been authorized by the manufacturer.

WARNING DUE TO UNAUTHORISED REPAIR!

Faulty repairs can result in damage to the appliance.

- Repairs should be carried out only by authorised customer service centers.
- If you cannot correct a fault with the aid of the steps described in these operating instructions, please refer to your authorised dealer.
- The electric safety of the machine is achieved only when the machine is correctly connected to a grounded electric system.
- The user shall arrange electric, water and draining systems in a suitable position to allow correct machine installation.

WARNING BEFORE SERVICING OR OPENING THIS DEVICE

Make sure the brewer is disconnected from power by pulling its plug. The service technician has to see the pulled plug during the whole service operation.

- The installer cannot modify the existing system built by the user.
- For good machine functioning and maintenance, it might be necessary to install a water softener in order to avoid scale formation. This must be evaluated by the installer and the user shall leave a space for the correct installation of a water softener, following the instructions contained in its manual.

DO NOT USE WATER JET DEVICES IN THE AREA WHERE TOUCH 04 IS INSTALLED!

DO NOT TILT TOUCH 04 DURING OPERATION! MAX. TILT ANGLE < 5°.

2. DESCRIPTION OF THE PRODUCT

2.1 Purpose of the Product

This machine shall be destined exclusively to the use it has been expressly designed for. Any other use shall be considered ill-suited and improper.

2.2 Contents

1x TOUCH 04 Brewer

1x Basket holder TO-305051

1x Shower head cpl. TO-200567

1x Manual Touch

1x Basket carrier TO-305052

1x Basket || TO-305053

1x Basket ||| TO-305054

1x Pressure reducer (4bar) incl. check valve TO-530196

1x Power cord incl. plug TO-200659

1x Water pipe Ø8mm incl. 3_8"/

Ø8mm fitting TO-200660

1x Base Cover TO-305059

2.3 APPLIANCE OVERVIEW

01 Power switch (on back side)

02 Four programmable buttons

03 Shower head

04 Brew basket holder 05 Brew basket

06 Thermos 4L (available separately)

CAUTION

Improper electrical installation will damage electronic components. Damage caused by incorrect electrical connections is not covered by warranty.

CAUTION

Power to brewer must be OFF before proceeding with plumbing installation.

2.4 DIMENSIONS

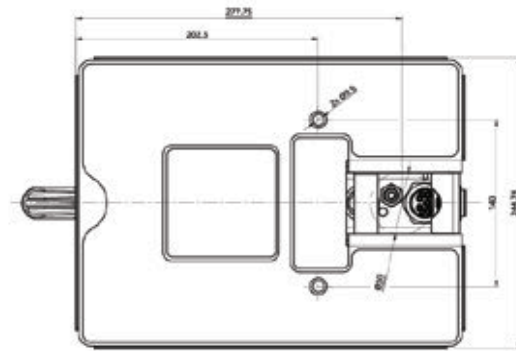

3. INITIAL USE

3.1 PLACE OF USE

- Brewer should be installed only inside and in a dry environment. Brewer should be installed on a secure, level, surface capable of fully supporting the weight of the brewer, including the water retained in the brewer, and any fully loaded dispenser(s) that may be placed on the brewer.
- A potable water line (cold water) capable of consistently supplying the required minimum flow rate within the noted pressure range is required at the install location.
- A grounded electrical connection to a circuit that meets the electrical specifications of the brewer and is protected by the appropriate size and type of breaker is required. See the supply cable specification in chapter 3.3.

CAUTION

Power to brewer must be off before proceeding with plumbing installation.

CAUTION

Improper electrical installation will damage electronic components. Damage caused by incorrect electrical connections is not covered by warranty.

3.2 PLUMBING CONNECTION

- The brewer must be rinsed after being connected to the water supply line. Remaining air in the system will be *removed (check point 3.4 Initial Set-Up)*. Otherwise it may lead to malfunctions and noise in the housing. Follow instructions in section Button functions.
- The pressure of the water line must be within 3-4 bar (a 4bar pressure reducer is included in the scope of delivery).
- The installation of a water softening filter system is mandatory for the use of TONE equipment. Any violation of this regulation will lead to a complete loss of any warranty on the complete system.

- The brewer has a descaling tracking function available. *Follow the instruction at point 4.2 Descaling.*
- Connect the water supply as follows: The new installation of the system shall every time be done with new hose sets. Please don't reuse old hose sets, those might be incompliant with the new installation set up. Hose sets are not part of the machine set. If you use detachable hose sets, then hose-set shall comply with EN 60335-2-75. The machine serves a water inlet, which can be changed to multiple requirements with several adapters from the market, to fit to the found environment needs (configuration of hose types on site etc.)

Standard IEC/EN 60335-1&IEC/EN 60335-2-75, required that "Appliances connected to the water mains constructed to prevent back siphonage of non-potable water." The machine has an internal backflow prevention. For the external back siphonage a adequate set of parts can be deployed.

3.3 ELECTRICAL CONNECTION

WARNING

The brewer must be disconnected from the power source until specified in INITIAL SET-UP.

CAUTION

Improper electrical installation will damage electronic components. Damage caused by incorrect electrical connections is not covered by warranty.

- An electrician must provide electrical service as specified in conformance with all local, state and federal electrical codes.
- If the supply cable is damaged, it must be replaced by the manufacturer, its service agent

or similarly qualified person in order to avoid a hazard.

- The electrical ratings can be found on the type plate which you will find on the device.
- Ensure power switch on rear of brewer is in the off position. Connect brewer to power source and verify voltage at terminal block. Replace rear panel and top cover. If plumbing has been hooked up, brewer is ready for Initial Set-Up. If not, disconnect brewer from power source.

WARNING

Electrical connections must be made as specified above. Failure to follow these instructions can result in personal injury, property or equipment damage.

WARNING

Before servicing or opening this device make sure the brewer is disconnected from power by pulling its plug. The service technician has to see the pulled plug during the whole service operation.

3.4 INITIAL SET-UP

- Remove the cover from the housing.
- Connect the blue water hose with the Touch 04 and your water supply. (Note: The TONE Touch

04 needs to be run with filtered water, check water specification on page 26).

- The water pressure should be between
- 0.1MPa and maximum 0.3 MPa (the flow of the machine is calibrated at the factory with
- 0.23 MPa). A pressure reducer is supplied with the machine to ensure that no more than 0.3 MPa of water pressure enters the machine. This ensures the machine can also be set up on pressure up to 0,6 MPa to the mains.
- Standard IEC/EN 60335-1&IEC/EN 60335-2-75, required that "Appliances connected to the water mains constructed to prevent back siphonage of non-potable water." The machine has an internal backflow prevention. For the external back siphonage a adequate set of parts can be deployed).
- The delivered connection adapter from TONE has a 3/8 inch thread.
- Build up a connection with a laptop or tablet to your Touch 04. Connection by ethernet cable to your laptop or connection by ethernet cable to a lan switch or connection over wifi with the IO-GEAR device. (*check point 4.3 Connecting*).
- Install the TONE Beverage Manager App on your device (iOS, Mac, Windows 10 or Android).
- Rinse the machine by pushing the buttons 1 & 2 and switch ON the main switch (the two buttons will shine up blue and cold water will rinse through the machine until you switch off the machine). This will help to get rid of the air inside of the brewer system. After rinsing a few milliliters turn the main switch OFF.
- Calibrate the flow of the machine to its new home before you use it. (*check point 4.6 Service.*)

4. PROCESS/WORKFLOW

4.1 BREWING

Carry out preparations for brewing and providing the correct filter size and basket inlet.

Select the desired recipe by pushing the corresponding button. As soon as the program is running the button starts to blink. Be aware that the water flow may be interrupted during the brewing process once or several times. Wait until the recipe is processed completely (button stops to blink).

The basket can be removed as soon as the buttons stop blinking. Until then, the basket will be locked if the locking mechanism TO-200618 is installed. Attention: If the locking mechanism is not installed, the basket can be pulled out at any time. Risk of burns!

Remove the brewing vessel from the appliance and the TONE Touch 04 is ready for use again immediately. The program can be aborted by pushing the chosen button again during process. *(Note: As soon as the button to end the current program is pressed, it continues to flash until the drip time has elapsed (check out chapter 4.4.1))*

There are four factory standard recipes installed on every Touch 04 (from left to right):

- 1** Volume: 300ml Taste: mild
- 2** Volume: 300ml Taste: medium
- 3** Volume: 300ml Taste: bold
- 4** Volume: 300ml Taste: xbold

The recipes can be exchanged or modified in the TONE Beverage Manager app. (Check *point 4.4* to learn how to create a recipe.

4.2 STARTUP MODES

Recipe selection:

Button 1 – 4 (from left to right)

Flush Mode:

Push and hold button 1 & 2 while switching the main switch ON. Stop the rinsing by switching the main switch OFF

- Rinse the device after a long-lasting down time or when there may be air inside the system.
- Before air transport or exposure to temperatures below 4°C all remaining water inside the brewer has to be removed. Disconnect the water supply and start the rinsing procedure.

IT IS NOT ALLOWED TO BLOW OUT THE MACHINE IN ANY WAY!

No blowing out with the mouth, no compressed air, no blowing out with the syringe, etc. This will destroy the sensitive flow meter!

Upon entering the flush mode, the machine will flush cold water through the brew head. After entering the flush mode, the user has several flushing options:

1. *Button 1 pressed:* Water flushes through bypass and only through flowmeter
2. *Button 2 pressed:* Water flushes through brew head and only through flowmeter 2.
3. *No button pressed or button 1 & 2 pressed:* Water flushes through brew head and through both flowmeters.

Descaling Mode

Push and hold Button 1 while switching the main switch ON. The descaling recipe will start immediately and last for about 12 minutes. As soon the button stops blinking the recipe is finished. Switching the machine OFF and ON again will bring you back into the standard mode.

Reset Mode

Push and hold Button 1 & 3 & 4 while switching the main switch ON. This mode will bring the four factory recipes (check chapter 4.1) back on each button.

Calibration Mode 1 (Flowmeter 1)

Push and hold Button 1 & 3 while switching the main switch ON.

After entering the flowmeter calibration mode, the user has the option to dispense a fixed volume of 500ml by clicking button 1. The actual measured volume can then be used to calibrate the flowmeter 1 via the app or directly on the machine. In order to calibrate the flowmeter on the machine, button 3 and 4 can be used. By clicking button 3, the flow calibration value is increased by 0.002. By clicking button 4, the flow calibration value is decreased by 0.002. Those actions can be done multiple times according to the user's need. After changing the calibration value, the user can again check the actual volume by pressing button 1, which will dispense 500ml with the updated calibration value.

Calibration Mode 2 (Flowmeter 2)

Same functionality as for flowmeter 1 calibration, but for flowmeter 2. To enter the mode push and hold Button 2&3 while switching the main switch ON.

Push and hold Button 1&2&3 while switching the main switch ON. This mode is for testing the sensors for the basket detection and the locking mechanism. Button 1 and 2 shows the position of the movable locking element. This is the element that gets push up and down when a basket is inserted. When button 1 lights up blue, it signals that the movable locking element has reached the lower sensor. When button 2 lights up blue, the upper sensor has reached as well.

By clicking button 3, the locking pin gets triggered. This will lock the movable locking element when its in the right position. It can be unlocked by clicking button 3 again. At the same time, button 3 will light up blue indicating that its correctly locked.

Error Codes

- No Flow – Button 3 & 4
- Waterheater Error – Button 2 & 3 & 4
- NTC Error – Button 1 & 4
- Basket Lock Error – Button 1 & 2 & 3 & 4

4.3 CONNECTING

OPTION 1A



Direct Connection

(direct or via a LAN-2-USB-C)

- connect the Touch 04 to your device
- only one Touch 04 can be connected to the tablet / pc

OPTION 1B

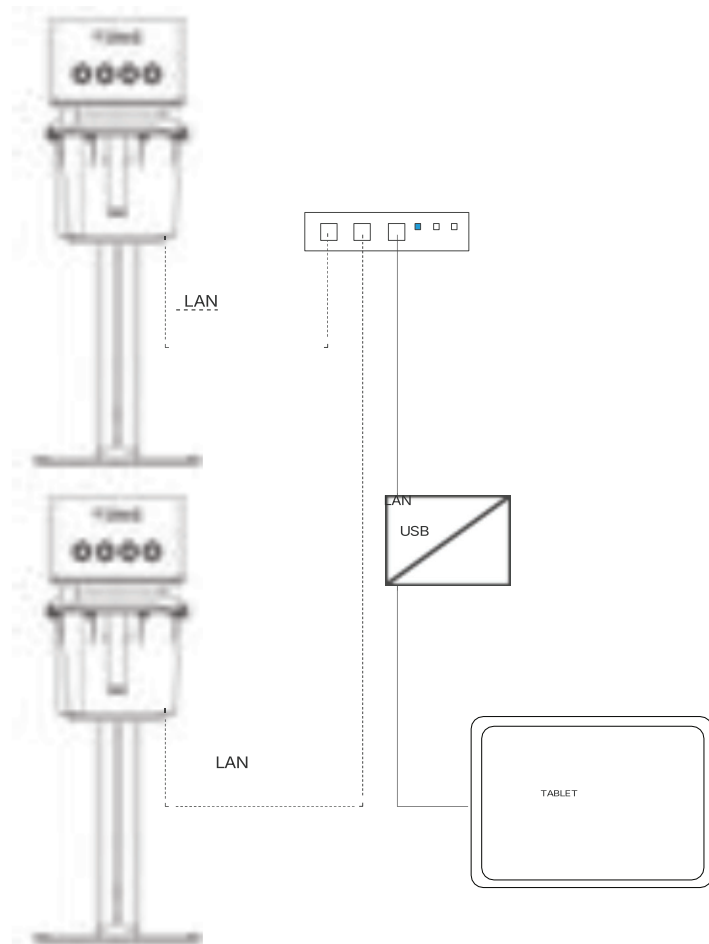

LAN-Switch / LAN-router

- connect the TONE to the LAN switch
- connect the LAN switch to the tablet / pc (direct or via LAN-2-USB converter)
- you can connect one or more TONE to the tablet / pc

NOTE:

The ethernet port configuration on your tablet / pc should be as follow:

1. connect the cable direct to your device or via the LAN-2-USB converter
2. Open the ethernet properties
Settings - Network and Internet – Ethernet – properties
3. Select automatic mode (dhcp) at the ip-assignment

OPTION 2A

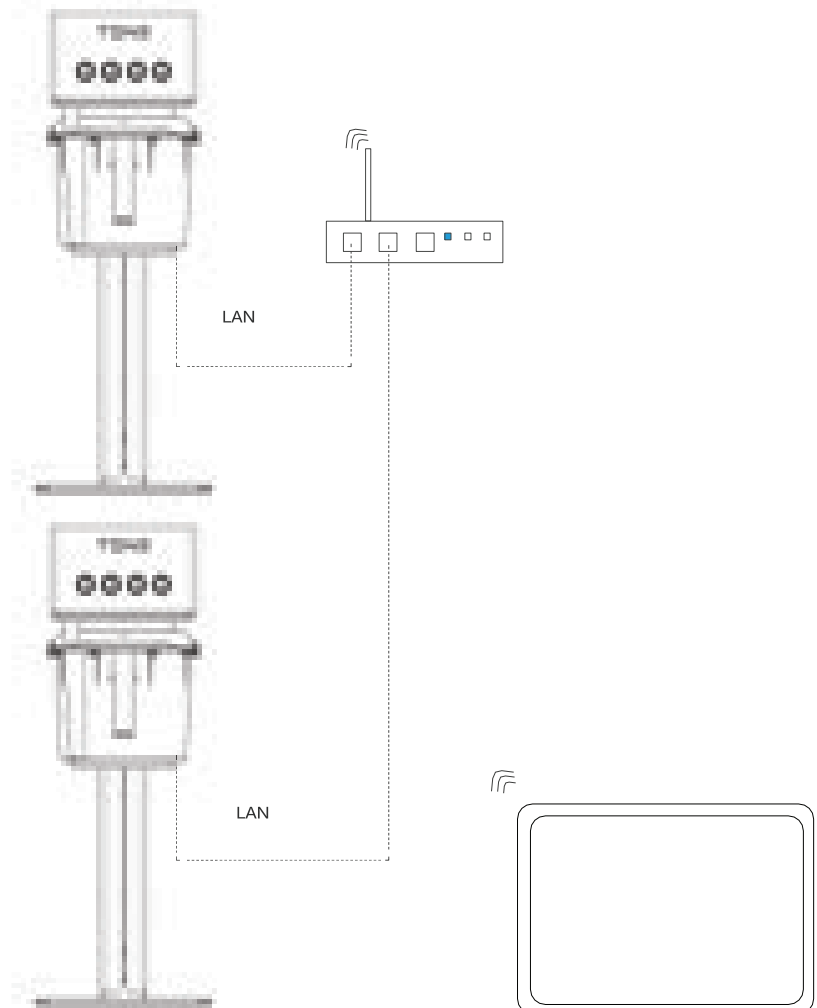

Wifi-Router

- connect the TONE to the wifi router
- connect the tablet / pc to the wifi router you can connect one or more TONE to the tablet / pc

OPTION 2B

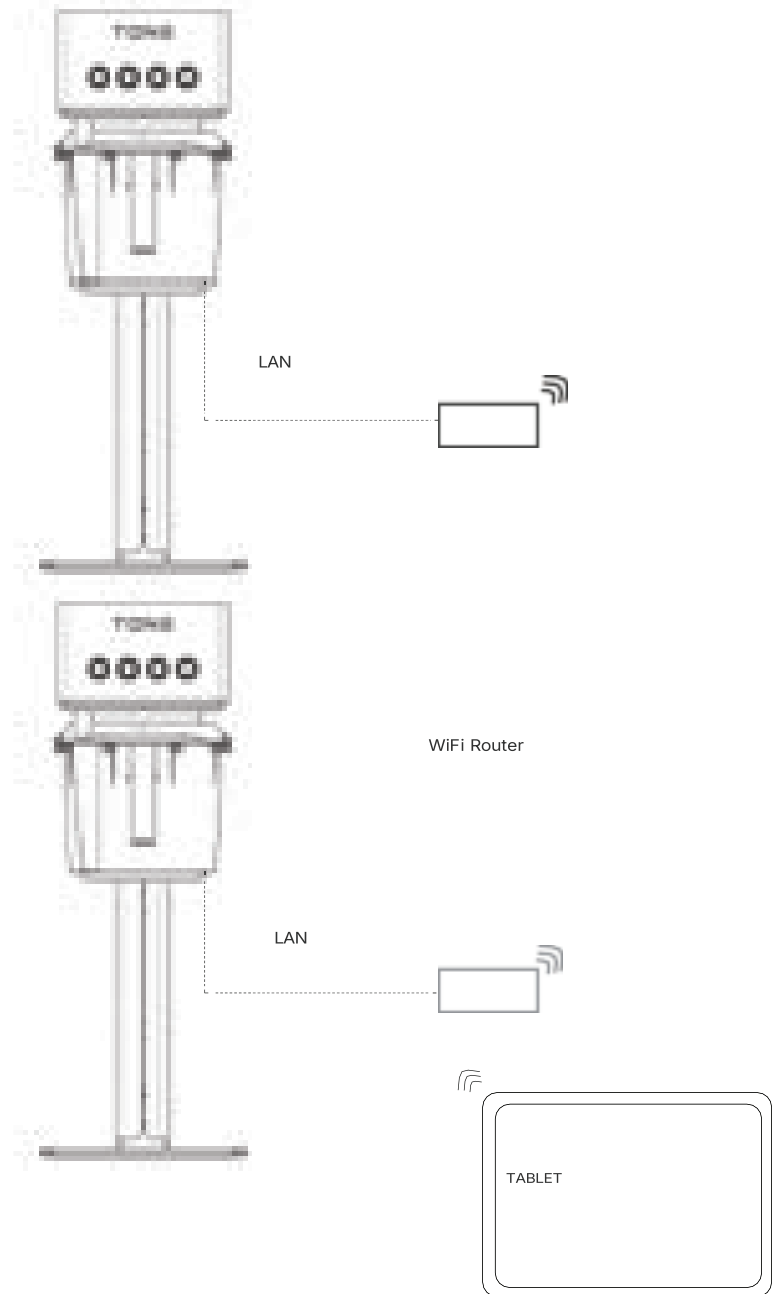

Ethernet-2-Wifi-Converter (IO-GEAR)

For each Touch 04 you need an Ethernet-2-Wifi Converter

- Consider the specific manual / video for the set-up on www.tone-swiss.com.

MAKE SURE THAT YOU DISABLE "LIMIT THE TRACKING OF YOUR IP-ADDRESS" ON ANY DEVICE YOUR TONE BEVERAGE MANAGER IS INSTALLED. IF THIS BUTTON IS NOT SWITCHED-OFF YOU MIGHT NOT SEE THE BREWER IN THE TONE BEVERAGE MANAGER.



4.4 EDIT RECIPES

(Connect your TONE Touch 04 brewer with the your tablet computer as described. Once the installation is complete, switch your TONE Touch 04 ON and it will appear in the list of available TONE equipment as soon you select the tab Touch 04. The factory pre-set name will be ToneTouch04_XXXXX (XXXXX=serial number). This can be customised later (s. Service tab).



Click on your device in the list and the standard configuration of the recipe selection buttons will be displayed. You can either change this configuration by clicking each button individually and chose recipes from the list which will be explained later. Or you can choose a whole set of recipes that you can put together (check point 4.4.2)

Please remark that your adaptations are made directly on the device. There is no need for a transfer command or a click on a confirmation checkbox here.



4.4.1 PROVEN MODE

The proven tab provides a tool for a quick and successful recipe creation. There are four pre-set options for coffee and three for tea, which will result in different strengths and extractions.

For the coffee recipes, the brewing temperature and the pulsation of the water flow is pre-defined by the TONE IBS (Intelligent Brewing System). You can simply enter how much ground coffees you are using (ratio), the total amount of water that hits the coffee, select a dilution in % or weight and its temperature, as well as an additional drip time, in case you desire it.

Enter the desired recipe name and click the save button. Your recipe will appear on the recipe list.

If you do not enter a specific name, the program will give you a name for the recipe, which includes the strength of the coffee, the amount of water and the quantity of ground coffee. The settings of the tea recipes are slightly different. Choose the water temperature considering the type of tea which shall be prepared. The different tea options differ regarding the number of pulses and their characteristics according to the IBS.

The name of a tea recipe will tell you the strength of the flavour, the amount of water and the brewing temperature.

If a recipe is no longer needed, you can delete it in this window by clicking on the trash bin and selecting the recipe(s) you no longer need. Then click on the green hook to delete.



4.4.2 CREATING SETS



It can be decided in advance whether the set is to be made for brewing profiles or for water profiles. This selection can easily be made using the brewing / water buttons.

You can compose a set of recipes by clicking on each button of the four square buttons. You can choose a recipe from the proven/ advanced and freestyle mode.

Once you have made your selection of recipes, press "save set", choose a meaningful name and select the desired category. Press then save again.



Press "select set" and select the desired set in the corresponding category. If you press "edit set" you can change one specific set or delete it if no more needed.

4.4.3 ADVANCED

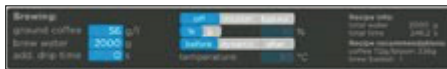

The Advanced tab provides you a very intuitive and comprehensive tool for the creation of new recipes. You can set the temperature of each extraction phase (bloom, turbulence, development) and define the characteristics of the water pulses (temperature, quantity, flow ratio, duration, interval).



First of all, you should fill out all the desired information in the black square box. Varying the bloom or the turbulence phase will adapt the development phase on the water quantity automatically.



Second, you can define how much coffee you need for your recipe by specifying the brew ratio. The amount of coffee is indicated in small letters below. In the same place, you will also see a recommendation of how much water is needed for the blooming phase (this can be transferred to the blooming column if required).



When you have finished your recipe, you can save it by giving the recipe the desired name and select whether it is a tea or coffee recipe. Then click "save recipe". Next, it will appear in the column when you press the desired key on your selected machine (Touch04) and it will select from the advanced chapter. There is also the possibility to change existing advanced recipes by clicking "edit recipe".

A new category can be done by pressing the + button in the advanced recipe list.



4.4.4 FREESTYLE

The freestyle chapter provides a way to create a recipe entirely without restrictions or frameworks.

As a first step, you can define the number of pulses (maximum 20) using the + and - keys. Further you can define the parameters per pulse individually. In the upper part you can see the total amount of water and the total time of the recipe.

After assigning a specific name and selecting Coffee or Tea, you can save the recipe with the „save recipe“ key. Again, it is also possible to modify existing recipes with the „edit recipe“ key.

4.4.5 WATER

As soon as the basket is removed, the buttons turn blue and the water mode is activated. The water chapter provides the option of drawing different quantities of water via the bypass. This is done at a defined temperature. Individual recipes up to a maximum of 4 liters can be linked to the 4 buttons. They also can be seen on the main page in blue letters below the button or on the button if you previous push on the water tab.

4.5 IMPORT/EXPORT FUNCTION

If you want to share a recipe you have created to someone, you can use the import

/ export function. Open the desired tab (proven, advanced or freestyle). Press the edit recipe button. Now you can decide whether you want to import a new recipe or export an existing one.



IMPORT

Select the button if you want to import a new recipe (sent to you from somewhere else) and retrieve the file from where you saved it on your device.



EXPORT

Select the button if you want to export a created recipe. The button will turn blue (see pic. 1) and you can now select all the recipes you want to export. Once you have done this, press the button again (the button will now have a green checkmark, see pic. 2) and select your desired memory location.

Once you have made your selection of recipes, press "save set", choose a meaningful name and select the desired category. Press then save again.



Pic 1



Pic 2

Please note that you can only import an Advanced recipe in the Advanced mode. This also applies to proven and freestyle mode.

4.6 SERVICE



The Service tab provides possibilities to customise the brewer identification and the calibration. And you can also check all important parameters. Clicking on the service tab will automatically open a login pop-up window. Entering the **password "TONEservice"** enables all available options. Select one of the brewers listed in the left column.

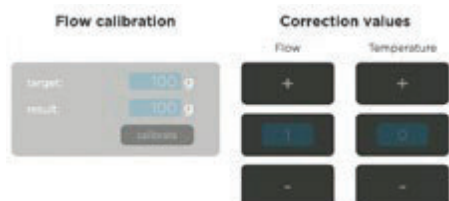

In the field "Location information" you can enter a meaningful description of your brewer and its location.

In case your brewer should extract more or less water than intended you can tweak the flow rate by setting a value below 1 in case you want to reduce the amount of water or a value above 1 if you want to increase the amount of water. This is a very sensitive tool and can only be adjusted in permille steps.

To access flow calibration mode, press buttons 1 and 3 for flow 1 and buttons 2 and 3 to access flow 2 calibration. Always simultaneously with the main switch ON. A 500g recipe can then be started with button 1.

For the exact calculation of the flow correction you can use the calculator. Enter the desired quantity (target) and the previously measured quantity in the "result" field. Then press the "calibrate" button to transfer the calculated correction to the "Flow" field. This correction is always added to or subtracted from the existing correction.

In case your extraction temperature doesn't fit to the set values of the recipes (e.g. when there is very cold water supply) you can adjust the temperature by clicking "+" or "-". The maximum values are +5/-5°C. Keep in mind that the maximum possible temperature of a recipe is limited at 97°C.

Theoretically you could then achieve a temperature

of 102°C. The heating system will then produce steam instead of water, which needs to be prevented in order to achieve good brewing results.

Please also remark that the boiling point of water drops with increasing altitude (≈

-1°C/300m).

With the “firmware update” button you can easily update the machine. Press the button, select the appropriate “file” on your device and upload it. (If necessary, you can download the actual firmware in the settings tab or ask your authorised dealer if a new file is available).

4.7 ERROR CODES

Buttons 1 & 4 light up blue.

1. Check if the NTC sensor cable (white) is disconnected.
2. Please, contact your dealer.

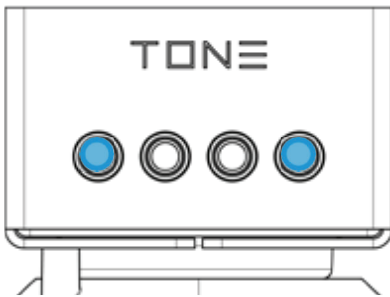

Button 1 & 3 & 4 light up blue.

- E-fast disconnected (violet cable).
- Both solid state relay. Disconnected (missing signal).
- Heating fuse defective.
- Cables on top of the heater are disconnected.

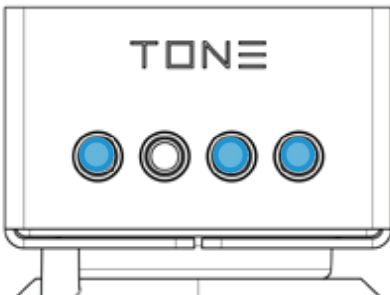

1. Save the current recipes on the machine via the TONE Beverage Manager. Do a reboot by pushing 1/3/4 and switch ON the main switch (this will delete the current recipes on the machine). Turn the machine off and on again.
2. Update the firmware to the latest version.
3. In case of any other issues, please contact your authorised dealer.

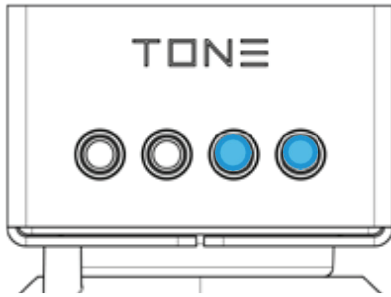

Buttons 3 & 4 light up blue.

No flow / water supply interrupted.

1. Check your water supply / open the main valve.
2. Rinse the machine with approx. 1L by pushing button 1/2 + main switch
3. Descale the machine (*check point 5.3: Descaling*)
4. If no water comes out, build out and clean the proportional valve
5. In case of any other issues, please contact your authorised dealer.

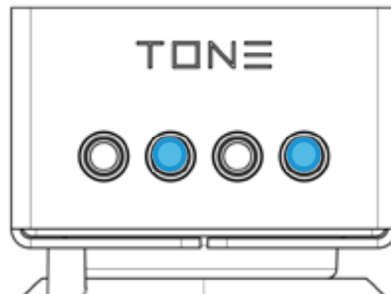

Buttons 2 & 4 light up blue.

- Proportional valve is leaking.
- Rinse the machine with approx. 1L by pushing button 1/2 + main switch.
- In case of any other issues, please contact your authorised dealer.

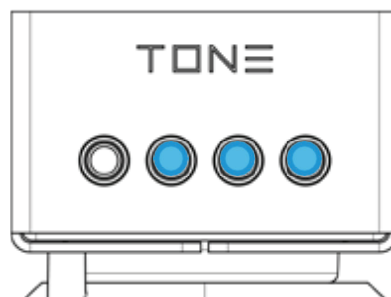

Buttons 2 & 3 & 4 light up blue.

- Brewer overheated / error on heating element / defective thermostat / Flow problem not resolved / missing signal from solid state relay.
1. Switch the brewer OFF and let it cool down.
 2. Rinse the machine with approx. 1L as described in *point 4.2: Rinsing*.
 3. In case of any other issues, please contact your authorised dealer.

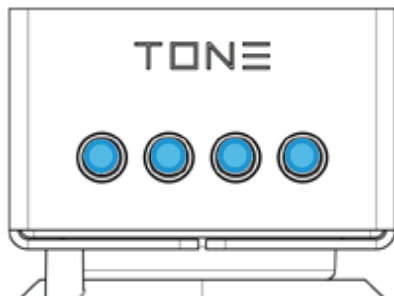

Buttons 1 & 2 & 3 & 4 light up blue.

- The basket could not be locked properly. Check the movement of the locking element
- Detach the carrier with the shower and then reattach it

For more precise information go to *point 5.2*.

Otherwise please contact your dealer.



Trouble shooting

If vibrating noises are heard from the machine housing, there could be air in the system. This can be the case in particular if the water supply line has been interrupted. In order to remedy the fault, the device must be rinsed. Follow the instruction in *point 4.2 Rinsing*.

In case of any other issues, please contact your dealer.

If the machine has the locking mechanism installed, it can simply be deactivated in the Service tab of the TONE Beverage Manager. This allows you to continue brewing if a locking error occurs.

5. MAINTENANCE

5.1 CLEANING

DANGER DUE TO IMPROPER CLEANING!

Improper cleaning can result in damage to the appliance or personal injury.

- To guarantee proper functionality of TONE equipment it is necessary to clean the device each day.
- To clean the surface of TONE equipment, it is recommended to use a damp cloth soaked in a 1% soda solution (Na₂CO₃).
- Never immerse the appliance itself, the power supply cable or plug in water.
- Never pull the plug out of the socket by the cable, always grasp the plug.
- Never attempt to touch or pick up an electrical appliance if it has fallen into water. In this case, disconnect the plug from the socket immediately.
- Check the appliance and cable regularly for damage.
- If you cannot correct a fault with the aid of the steps described in these operating instructions, please refer to your authorised dealer.

5.2 DAILY CLEANING

- Do not use water jet device to clean the TONE equipment.
- Do not use abrasive means to clean the TONE equipment.
- Check and clean the showerhead daily. All holes of the spray head must always remain open.
- Flush the machine every day with approx. 2L cold water. Before this can be done, a container (volume 2L) should be placed under the shower.

NOTE - Any remains on the showerhead may influence the water flow and impact your coffee brewing.

DANGER DUE TO UNAUTHORISED REPAIR!

Repairs should be carried out only by authorized customer service centres.

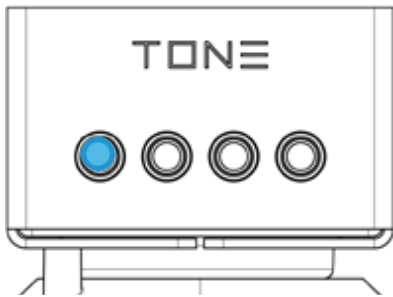

5.3 DESCALING

To guarantee proper functionality of TONE equipment, it is necessary to descale the device.

Please note: The descaling of the TONE Touch 04 brewing system is mandatory as soon the chasing light is appearing or at least once a month.

Any violation of this regulation will lead to a loss of any warranty on the whole brewer.

The demand of a descaling process is indicated on the recipe buttons by a blue chasing light:

Blue chasing light (**Button 1-4**) after switching the brewer ON and after finishing a recipe

- Descaling necessary

This signal is shown after switching the machine ON and at the end of every extraction.



Step 1

Remove the cover from the TONE Touch 04.



Step 2

Before the descaling process is started, a vessel with a minimum volume of one liter must be placed underneath the shower.



Step 3

Remove the lid from the descaling agent container.

Step 4

Screw the descaling agent container into the descaling valve. If the bottle can only be screwed in with great effort, apply a little food grade grease to the thread.

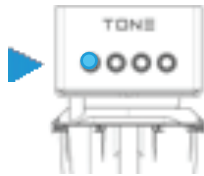

Step 5

Push and hold button one while switching the machine ON again.

Step 6

Allow the decalcification recipe (duration approx. 12) to run through completely. As soon as the min descaling is completed, button one shines constantly blue.



Step 7

Remove the descaling agent container and restart the machine.

Step 8

Flush the whole system by extracting at least 300 gramm of hot water.

Step 9

The TONE Touch 04 is then ready again for brewing excellent coffee.

5.4 TOUCH 04 EQUIPMENT

Provided with the machine:

- Brew basket
- 2 inlets for the basket Size 2 = Brews for 1.0-3L
Size 3 = Brews for 2.5-4L
- Starterkit of filter papers (each 25 pcs): Size 2 = Ø320/110
- Size 3 = Ø360/156

Available as option:

- Bag of filter paper with 500 pcs: Filterpaper Size 2 = Ø320/110 Filterpaper Size 3 = Ø360/156
- TONE Green Clean (descaling liquid): one design carton includes 12 green clean bottles x 29 ml - suitable for one year cleaning.
(Available at your authorised TONE dealership)

6. FAULT RECTIFICATION

PROBLEM	SOLUTION
Overheating (Buttons 1 & 4 light up blue)	<ol style="list-style-type: none"> 1. Check if any of the NTC sensor cable (white) is disconnected 2. Please, contact your dealer.
No recipes visible on the keys (TONE-App)	<ol style="list-style-type: none"> 1. Check if the number of the machine on the left side is marked. 2. Do a reboot of the machine by pushing 1/3/4 and main switch together. 3. Update the machine with the actual firmware. 4. In case of any other issues, please contact your dealer.
Dripping from the machine even when the machine is switched off	<ol style="list-style-type: none"> 1. Rinse the machine with approx. 1L by pushing button 1/2 and main switch together. 2. Descale the machine (check manual). 3. In case of any other issues, please contact your dealer.
No flow / water supply interrupted Buttons 3 & 4 light up blue	<ol style="list-style-type: none"> 1. Check your water supply / open the main valve. 2. Rinse the machine with approx. 1L by pushing button 1/2 + main switch. 3. Descale the machine. 4. Please, contact your dealer if there is an issue.
Buttons 2 & 4 light up blue -> Proportional valve is leaking	<ol style="list-style-type: none"> 1. Rinse the machine with approx. 1L by pushing button 1/2 + main switch. 2. Please, contact your dealer.
Buttons 2 & 3 & 4 light up blue Brewer overheated / error on heating element / defective thermostat / Flow problem not resolved / missing signal from solid state relay.	<ol style="list-style-type: none"> 2. Switch the brewer OFF and let it cool down. 3. Rinse the machine with approx. 1L by pushing button 1/2 main switch together. 4. Please, contact your dealer if there is an issue.
The machine is heavy sputtering at the beginning of each pulse.	<ol style="list-style-type: none"> 1. Please, contact your dealer.

PROBLEM	TIP
When starting a recipe, no water comes out of the machine (the selected button keeps blinking)	<ol style="list-style-type: none"> 1. Check the fuse of the heating element. 2. Check if during the run of a recipe the LED of both solid state relays are blinking. 3. Update the firmware. 4. In case of any other issues, please contact your dealer.
The machine is not visible in the TONE App (Connection is done by ethernet cable)	<ol style="list-style-type: none"> 1. Check the regulations of your firewall for the TONE app. 2. Select the automatic mode in the ethernet properties. 3. Switch off/ on the machine and the TONE App 4. Check if the machine number is visible in the TONE App 5. In case of any other issues, please contact your authorised dealer.
The machine is not visible in the TONE App (Connection is done over wifi with the IO-GEAR device)	Check the setup of the IO-GEAR device regarding the manual "IO-GEAR Setup" (check video and document on www.tone-swiss.com)

7. TECHNICAL DATA

Type	TOUCH 04
Designation	Beverage maker
Dimensions in mm (wxhxd)	242 x 647 x 320
Weight	22 kg
Boilervolume	Boilerless
Maximal waterflow	16g/sec
Required water pressure	0.1-0.4 MPa
Maximal water pressure	0.6 MPa
Noise level	< 50 dB

The electrical ratings can be found on the type plate which you will find on the device.

8. RECYCLING AND DISPOSAL

Instructions for the disposal of old products. The WEEE Directive (Waste from electrical and electronic equipment; 2002/96/EG) was passed for the protection of human health and the environment, in order to ensure that old products are disposed of so as to make use of the best possible recovery and technical recycling possibilities.

Your product has been developed and manufactured from high-quality materials and components, which can be largely recovered and recycled. Do not dispose of the product as normal domestic waste. Please find your local collection points for electrical and electronic waste products, which are marked with this symbol:

Please make use of one of the following disposal possibilities:



1. Dispose of the complete product (including the cable, plug and accessories) at the relevant WEEE collection point.
2. If you are buying a replacement product, you can return the old appliance to the dealer. Under the WEEE Directive, retailers are obliged to take back such old appliances.

9. WIRING DIAGRAM

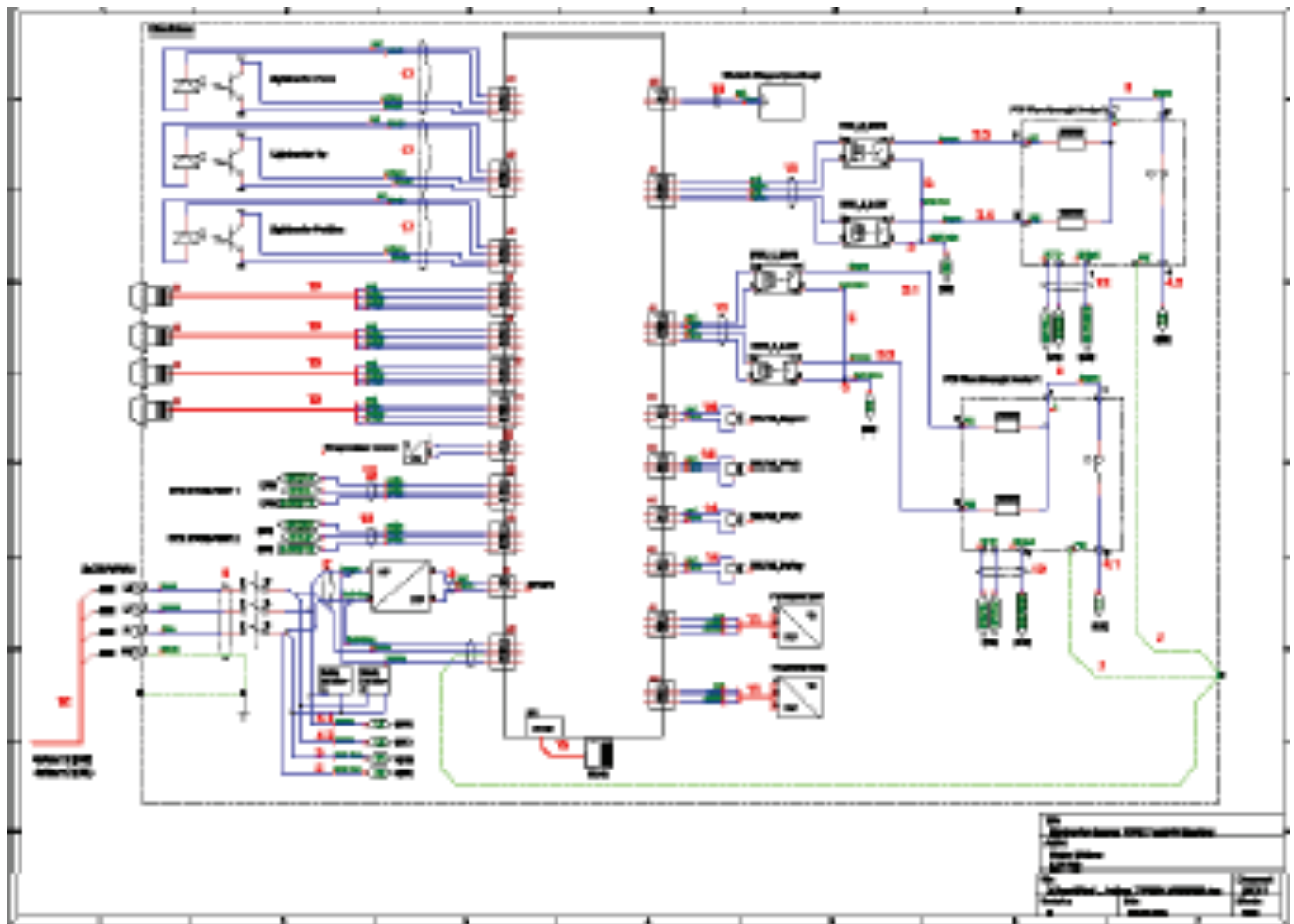

10. TONE WATER SPECIFICATION
Recommended water parameters for TONE
TOUCH 04

VALUE	UNITS	MINIMUM	Above this values a decarbonation is necessary	MAXIMUM
Conductivity/T.D.S	μS ppm	120 60	180 100	300 160
Total Hardness	ppm dH	50 3	100 7	160 9
Total Iron	ppm			0,2 mg/l
Free Chlorine	ppm	free from chlorine and chlorine compounds		
Total Chlorine	ppm			
pH		6		8
Alkalinity	ppm	36		107
Carbonate Hardness	dH	2	4	6
Chloride	ppm	0		30

TONÉ

CUP&CINO Kaffeesystem-Vertrieb GmbH & Co. KG,
Paderborner Str. 33, 33161 Hövelhof, Germany
+49 5257 98 98 40 4, www.latteartfactory.com,
info@latteartfactory.com